

MARK	DATE	ECO NO.	DESCRIPTION	REV.	DESIGN
①			首版发行	1	Eric

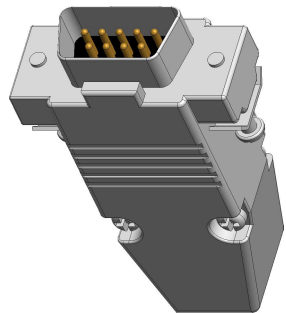

DB-9-01 (公)

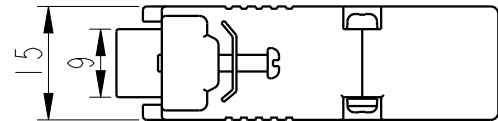
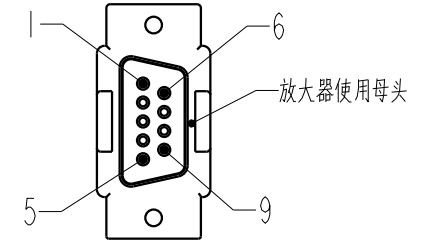
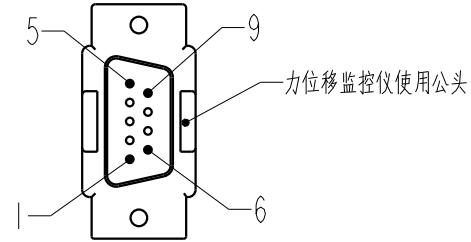
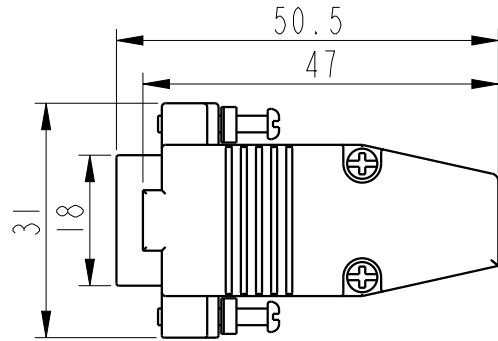
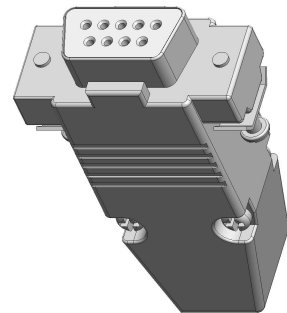

DB-9-02 (母)

DB-9插头接线定义

序号	定义	说明
1	E+	传感器E+
2	S+	传感器S+
3*	Sen-	传感器Sen-
4	GND	GND
5	NG	空
6*	Sen+	传感器Sen+
7	S-	传感器S-
8	E-	传感器E-
9	NG	空

*为六线制接线方法（四线制可以忽略）

BEDELL		苏州比得电子技术有限公司	
		suzhou Bedell Electric Technology Ltd	
DATE	23/8/11	TITLE	DB-9插头
DESIGN	Eric	PART NO.	
VERIFIED		UNITS	mm
APPROVED		SCALE	1:1
		PAGE	1/1
		REV	1

未标注尺寸公差 (±)

尺寸	A	B	C	D
X ≤ 4	0.05	0.1	0.2	0.3
4 < X ≤ 16	0.1	0.2	0.3	0.4
16 < X ≤ 63	0.2	0.3	0.4	0.7
63 < X ≤ 250	0.3	0.4	0.5	1.2
X > 250	0.4	0.5	0.8	2.0